

## Style 4 Street Barrier Dimensions:

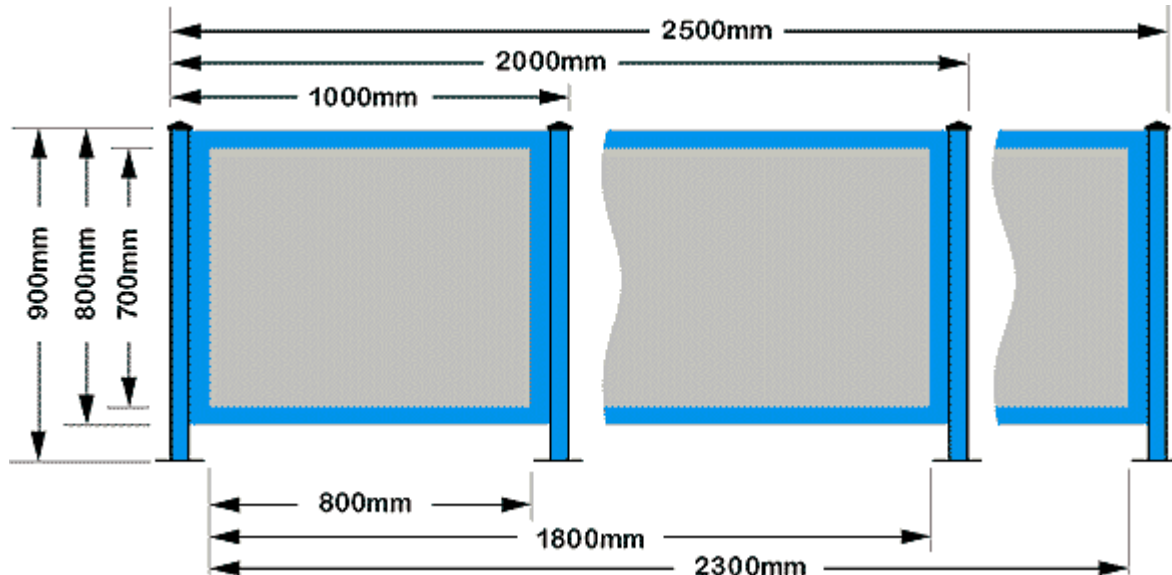

- Standard Finish:** Powder-coated 50mm square section aluminium columns with feet. (custom capitals available)  
Powder-coated 50mm wide exclusive section aluminium frames  
Vinyl insert panel fixed into frame on all sides.
- Artwork Area:** Maximum recommended area for **computer-cut** and **screen-print** artwork:  
1m - 650mm(H) x 750mm(W)  
2m - 650mm(H) x 1750mm(W)  
2.5m - 650mm(H) x 2250mm(W)
- Digitally Printed** (full coverage):  
1m - 'canvas' size 750mm (H) x 850mm (W) ( viewing area 700H x 800W plus 25mm bleed on each side)  
2m - 'canvas' size 750mm (H) x 1850mm (W) (view area 700H x 1800W plus 25mm bleed on each side)  
2.5m - 'canvas' size 750mm (H) x 2350mm (W) (view area 700H x 2300W plus 25mm bleed on each side)
- NOTE:** Some Council By-Laws restrict the area which signage may cover

**NOTE:** Some Council By-Laws restrict the area which signage may cover

**Artwork for Printing:** Artwork to be used for digitally printed barriers is preferred as an **EPS** file or a **high quality 'JPEG'**.

**Electronic File Formats:** Artwork may be contained in files with formats including "eps", "ai" (up to V10.0) and "jpg".

**Submission of Artwork:** Artwork is submitted in electronic formats via Email or on Floppy Disc (1.44Mb PC/Mac), ZIP Disc (100Mb PC) or CD Compact Disc (PC format only).

Where artwork is submitted in a format ready for reproduction with little or no editing, no additional charges apply for graphics up to two colours for vinyl cutting or screen printing, however conversion of bitmap files to vector format for vinyl cutting or lithographic film production, extraction of 'embedded' bitmaps from non-graphical formats, importing of file formats not supported by the Awnet Art Department, reconstruction or major editing of artwork will incur an additional charge.

**NOTE:** It is not always possible to exactly match vinyl film colours to "PMS" colours or other colours specified in submitted artwork, however the best match will be made using the most suitable vinyl films.

**PLEASE NOTE:** Files in "eps" or "ai" format should have any FONTS CONVERTED TO GRAPHICS and line widths or stroking CONVERTED TO OUTLINES to avoid an additional editing charge.