

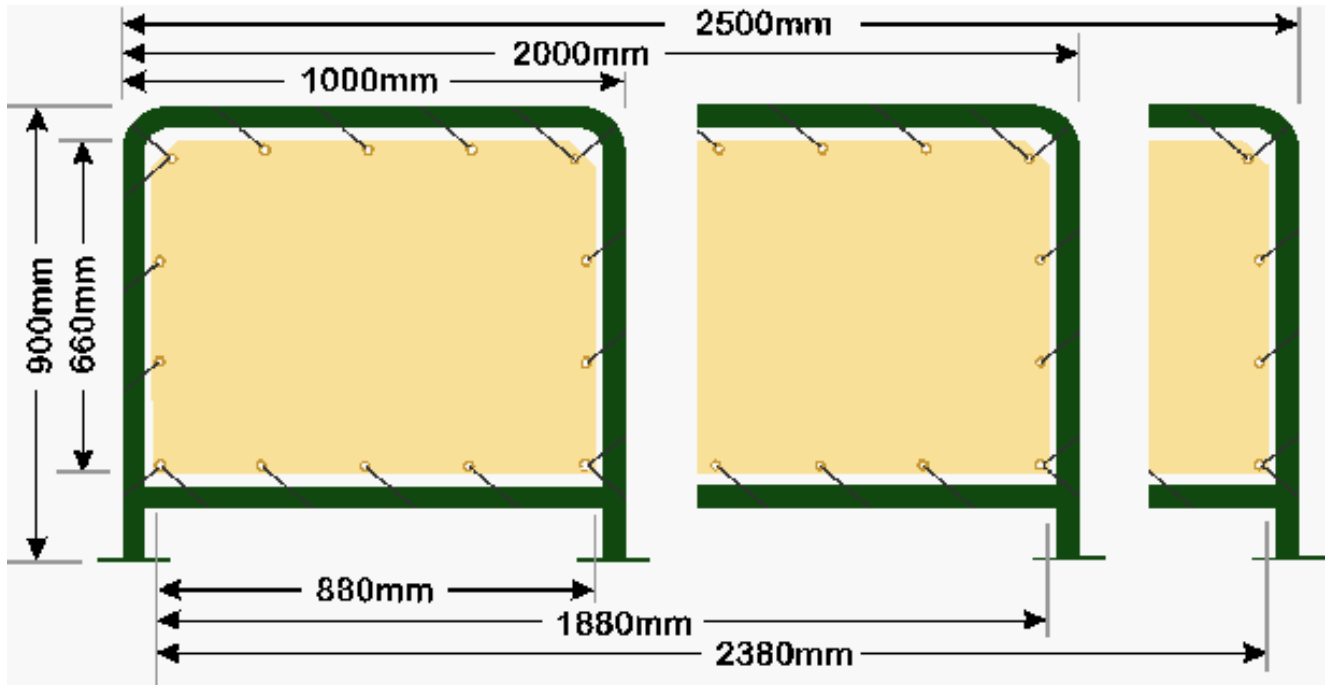

Style 1 Street Barrier Dimensions:



- Standard Finish:** Powder-coated 45mm tubular steel frames with feet.
Rope and eyelet laced vinyl insert panel.
- Weight (incl. feet):** 9.0Kg - 1m (typical), 13.0Kg - 2m (typical), 15.0Kg - 2.5m (typical).

- Artwork Area:** Recommended maximum area for **computer-cut** and **screen-print** artwork:
1m - 600mm (H) x 820mm (W)
2m - 600mm (H) x 1820mm (W)
2.5m - 600mm (H) x 2320mm (W)
- Digitally Printed** (full coverage):
1m - 'canvas' size 720mm (H) x 940mm (W) (viewing area 660H x 880W plus 30mm bleed on each side)
2m - 'canvas' size 720mm (H) x 1940mm (W) (view area 660H x 1880W plus 30mm bleed on each side)
2.5m - 'canvas' size 720mm (H) x 2440mm (W) (view area 660H x 2380W plus 30mm bleed on each side)

NOTE: Some Council By-Laws restrict the area which signage may cover

Artwork for Printing: Artwork to be used for digitally printed barriers is preferred as an **EPS** file or a **high quality 'JPEG'**.

Electronic File Formats: Artwork may be contained in files with formats including "eps", "ai" (up to V10.0) and "jpg".

Submission of Artwork: Artwork is submitted in electronic formats via Email or on Floppy Disc (1.44Mb PC/Mac), ZIP Disc (100Mb PC) or CD Compact Disc (PC format only).

Where artwork is submitted in a format ready for reproduction with little or no editing, no additional charges apply for graphics up to two colours for vinyl cutting or screen printing, however conversion of bitmap files to vector format for vinyl cutting or lithographic film production, extraction of 'embedded' bitmaps from non-graphical formats, importing of file formats not supported by the Awnet Art Department, reconstruction or major editing of artwork will incur an additional charge.

NOTE: It is not always possible to exactly match vinyl film colours to "PMS" colours or other colours specified in submitted artwork, however the best match will be made using the most suitable vinyl films.

PLEASE NOTE: Files in "eps" or "ai" format should have any FONTS CONVERTED TO GRAPHICS and line widths or stroking CONVERTED TO OUTLINES to avoid an additional editing charge.